

DO NOT SCALE

04/11/2016

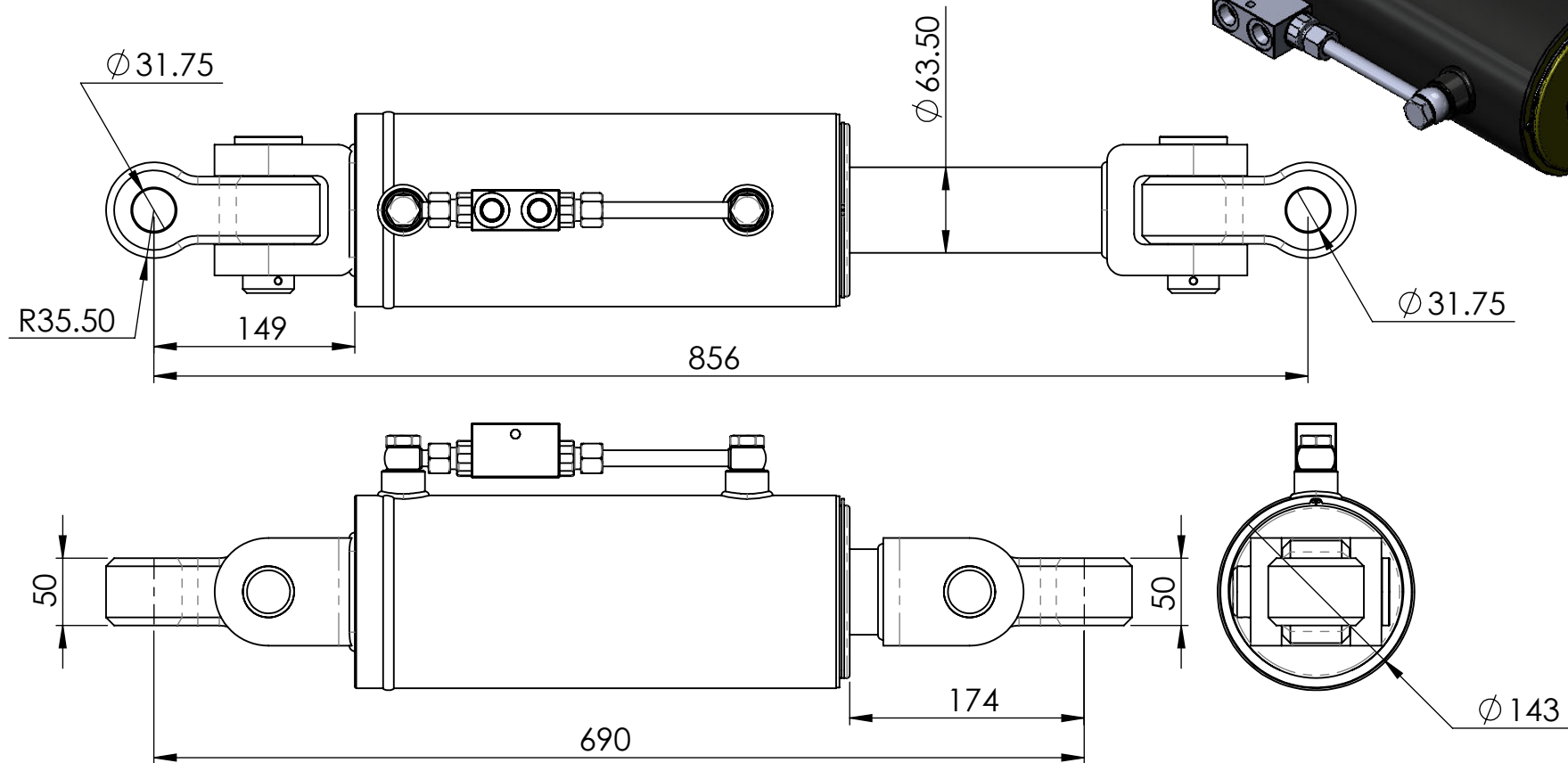
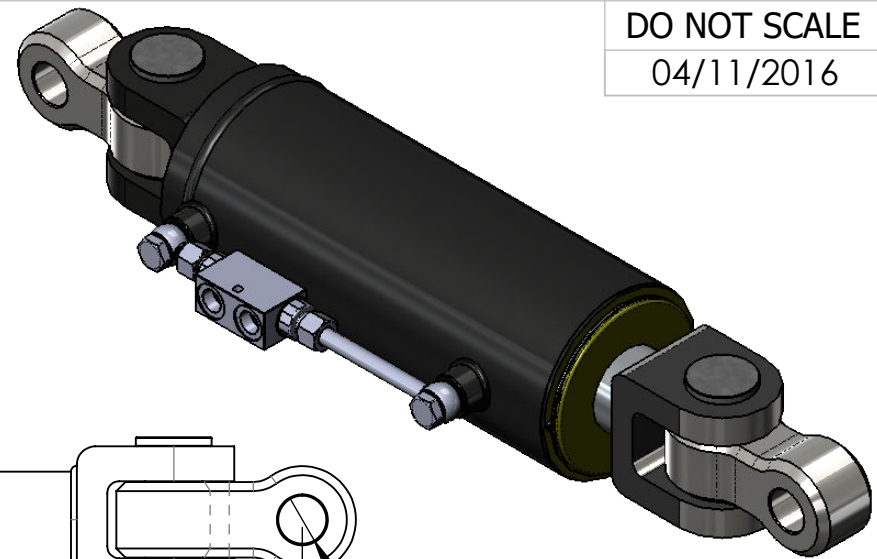

FOR 250+ HP TRACTORS

The information contained in this drawing is proprietary to MOTUS and shall not be reproduced or disclosed in whole or in part or used for any design or manufacture except when such user possesses direct written authorisation from MOTUS

Ram Phone: 0800 66 88 74  
 Phone: +64 6 879 8590  
 sales@motushydraulics.co.nz  
 www.motushydraulics.co.nz

DESCRIPTION	TL-X CAT3	RATED OPERATING PRESSURE: 3000 p.s.i	
SEAL KIT No:	SK500250	FORCE RETRACT	14720 kG @ 2250 psi
FORCE EXTENSION	19630 Kg @ 2250 psi	PORTS	3/8 BSPP F
STROKE	166mm	BASE MOUNT	CAT 3 KNUCKLE
CLOSED CENTRES	690mm	SHAFT MOUNT	CAT 3 KNUCKLE
OPEN CENTRES	856mm		